

Mechanically Jointed Rodless Cylinder/Linear Guide Type

Series MY2H/HT

ø16
ø25
ø40

Replacement
Procedure is
P.311

Construction

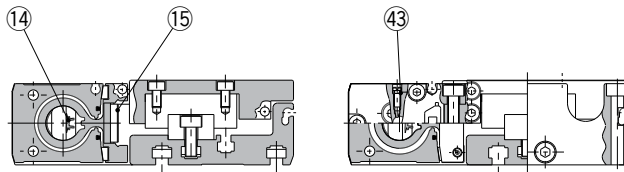
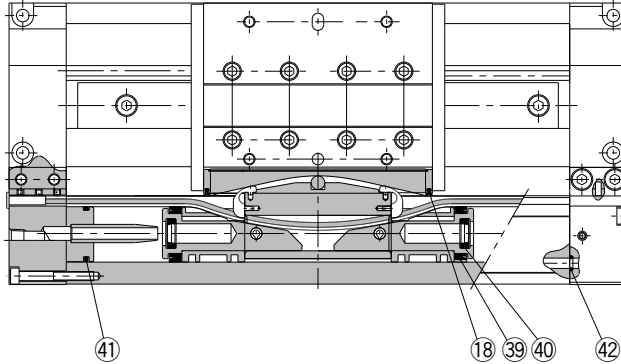

* The numbers are the same as the "Construction" of the Best Pneumatics No.2 Series MY2H/HT.

*[BLUE](#) links will lead to purchase pages.
Call or email us at sales@smcpneumatics.com for request.

Replacement Parts: Seal Kit

No.	Description	Qty.	MY2H16G/MY2HT16G	MY2H25G/MY2HT25G	MY2H40G/MY2HT40G	Note
14	Seal belt	1	MY16-16A- Stroke	MY25-16A- Stroke	MY40-16A- Stroke	14, 15 and 43 are not included in the seal kit. Order them as required with by individual part numbers.
15	Dust seal band	1	MY2H16-16B- Stroke	MY2H25-16B- Stroke	MY2H40-16B- Stroke	
43	O-ring	2	KA00309 (ø4 x ø1.8 x ø1.1)	KA00309 (ø4 x ø1.8 x ø1.1)	KA00320 (ø7.15 x ø3.75 x ø1.7)	
18	Scraper	2	MY2B16-PS	MY2B25-PS	MY2B40-PS	
39	Piston seal	2				
40	Cushion seal	2				
41	Tube gasket	2				
42	O-ring	4				

* Seal kit includes 18, 39, 40, 41 and 42. Order the seal kit based on each bore size.

* Seal kit includes a grease pack (10 g).

When 14 and 15 are shipped as single units, a grease pack (20 g) is included.

Order with the following part number when only the grease pack is needed.

Grease pack part no.: GR-S-010 (10 g) , GR-S-020 (20 g)