

Construction

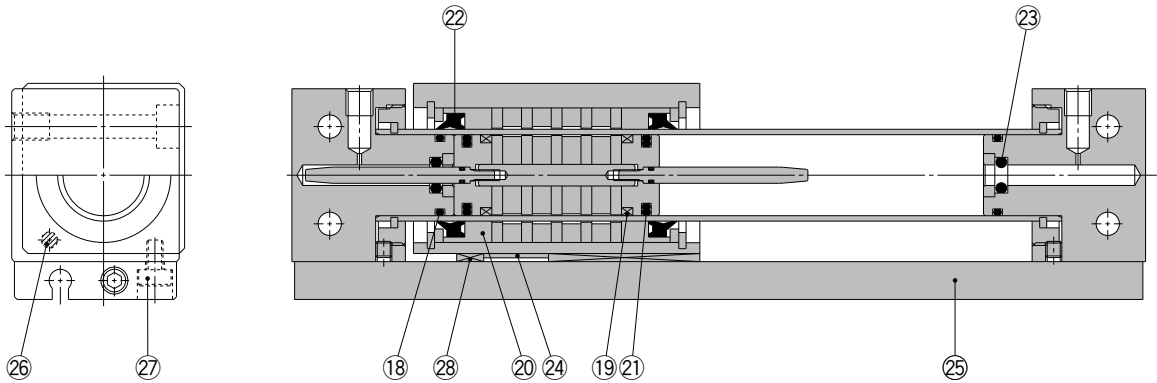

- * The numbers are the same as the "Construction" of the Best Pneumatics No.3 Series REAR.
- * The figure is for ø15. (The magnet for ø10 : 3 pcs.)

Seal Kit List

No.	Description	Material	Note
18	Cylinder tube gasket	NBR	
19	Wear ring A	Special resin	ø10: not available
20	Wear ring B	Special resin	
21	Piston seal	NBR	
22	Scraper	NBR	
23	Cushion seal	NBR	
24	Magnetic shielding plate	Rolled steel plate	Chromated
25	Switch rail	Aluminum alloy	Clear anodized
26	Magnet	—	
27	Hexagon socket head cap screw	Chromium steel	Nickel plated
28	Wear ring C	Special resin	

24 to 27 are non-replaceable parts, so they are not included in the seal kit.

*[BLUE](#) links will lead to purchase pages.

Replacement Parts: Seal Kit

Bore size (mm)	Kit no.	Contents
10	REAR10-PS	Set of left nos. 18, 20, 21, 22, 23, 28
15	REAR15-PS	Set of left nos. 18, 19, 20, 21, 22, 23, 28 ^{Note)}

Note 1) It may be difficult to replace the cushion seal 23.

Note 2) For wear ring A of ø10, please consult with SMC.

* Seal kit includes a grease pack (ø10: 5 g and 10 g, ø15: 10 g).

Order with the following part number when only the grease pack is needed.

For ø10 grease pack part no.: **GR-F-005** (5 g) for external sliding part

GR-S-010 (10 g) for tube interior

For ø15 grease pack part no.: **GR-S-010** (10 g)

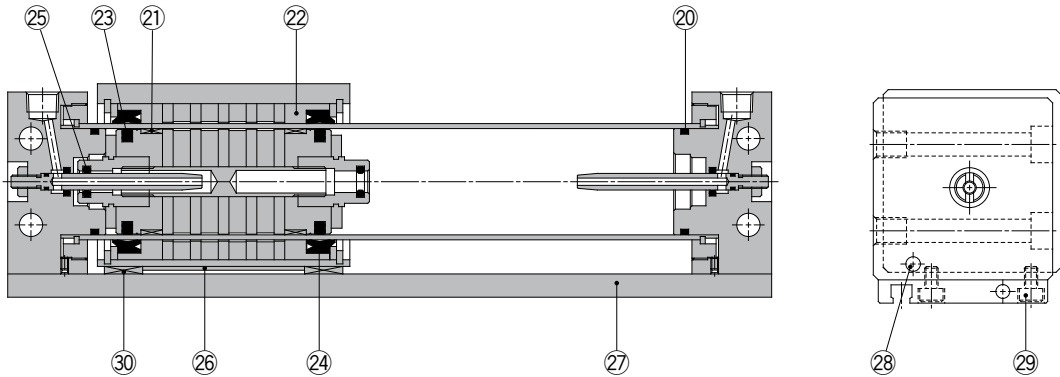
Construction

* The numbers are the same as the "Construction" of the Best Pneumatics No.3 Series REAR.

*[BLUE](#) links will lead to purchase pages.

Seal Kit List

No.	Description	Material	Note
20	Cylinder tube gasket	NBR	
21	Wear ring A	Special resin	
22	Wear ring B	Special resin	
23	Piston seal	NBR	
24	Scraper	NBR	
25	Cushion seal	NBR	Chromated
26	Magnetic shielding plate	Rolled steel plate	Clear anodized
27	Switch rail	Aluminum alloy	
28	Magnet	—	Nickel plated
29	Hexagon socket head cap screw	Chromium steel	
30	Wear ring C	Special resin	

26 to 29 are non-replaceable parts, so they are not included in the seal kit.

Replacement Parts: Seal Kit

Bore size (mm)	Kit no.	Contents
20	REAR20-PS	Set of left nos. 20, 21, 22, 23, 24, 25, 30 <small>Note)</small>
25	REAR25-PS	
32	REAR32-PS	
40	REAR40-PS	

Note) Cushion seal 25 may be difficult to be replaced.

Note) Seal kit includes 20 to 25, 30. Order the seal kit, based on each bore size.

* Seal kit includes a grease pack (10 g).
Order with the following part number when only the grease pack is needed.

Grease pack part no.: GR-S-010 (10 g)