

Series MGP-□Z

Replacement
Procedure is
p.333

Construction: Series MGPM, MGPL, MGPA

MGPM12 to 25

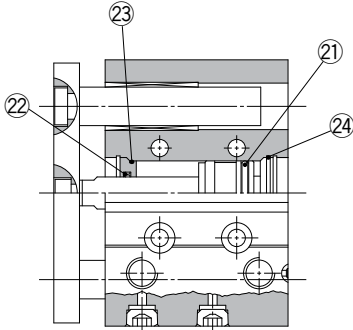

MGPM32 to 100

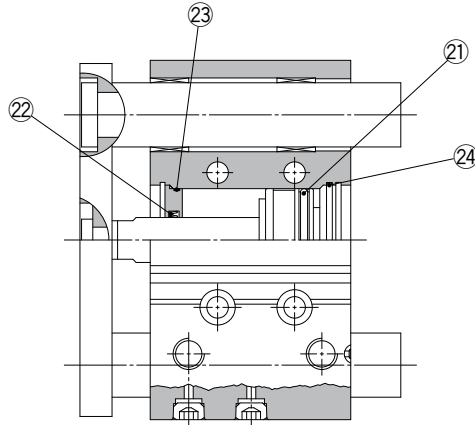

MGPL12 to 25
MGPA12 to 25

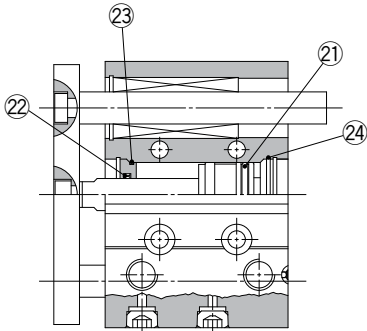

MGPL32 to 100
MGPA32 to 100

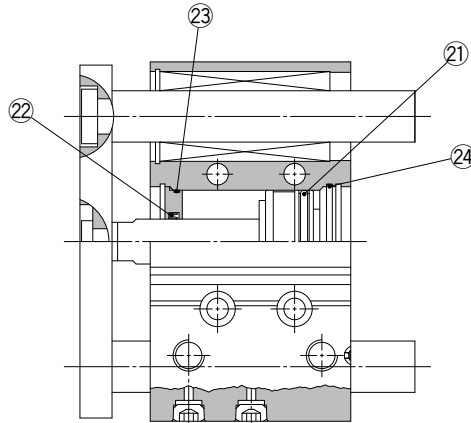

* The numbers are the same as the "Construction" of the MGP series catalog (CAT.ES20-219).

Seal Kit List

No.	Description	Material	Note
①	Piston seal	NBR	
②	Rod seal		
③	Gasket A		
④	Gasket B		

*[BLUE](#) links will lead to purchase pages.

Replacement Parts: Seal Kit

Bore size (mm)	Kit no.	Contents	Bore size (mm)	Kit no.	Contents
12	MGP12-Z-PS	Set of left nos. ①, ②, ③, ④	40	MGP40-Z-PS	Set of left nos. ①, ②, ③, ④
16	MGP16-Z-PS		50	MGP50-Z-PS	
20	MGP20-Z-PS		63	MGP63-Z-PS	
25	MGP25-Z-PS		80	MGP80-Z-PS	
32	MGP32-Z-PS		100	MGP100-Z-PS	

* Seal kit includes ① to ④. Order the seal kit, based on each bore size.
* Since the seal kit does not include a grease pack, order it separately.
Grease pack part no.: GR-S-010 (10 g)

Actuators

Modular F.R.L.
Pressure Control Equipment

Air Preparation
Equipment

Industrial Filters

Replacement
Procedure

Actuators

Modular F.R.L.
Pressure Control Equipment

Industrial Filters